

<h1>Structural Steel Design Project</h1> <h2>Calculation Sheet</h2>	Job No:	Sheet 1 of 10	Rev
	Job Title: <i>TRUSS GIRDER RAIL BRIDGE</i>		
	<i>Worked Example - 1</i>		
	Made by	SSSR	Date 8-10-00
Checked by	VK	Date	

**PROBLEM:**

Design a through type single lane truss bridge for broad gauge main line loading. The effective span length of the bridge is 50 m. Consider  $\gamma_m = 1.15$ .

**(1) TRUSS ARRANGEMENT [See Fig. E1]:**

Effective Span of truss girder = 50 m.

Assume 10 panels @ 5 m interval.

Height and truss girder:

For economical considerations, height =  $\frac{1}{8}$  to  $\frac{1}{10}$  of span

Assume, height = 6m. ( $\frac{1}{8.33}$  of span) Hence, O.K.

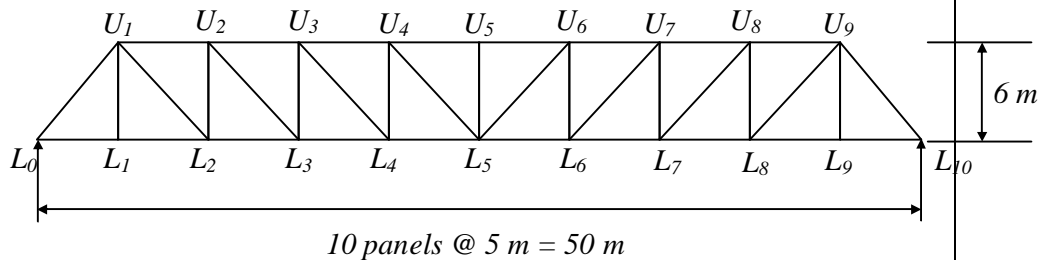
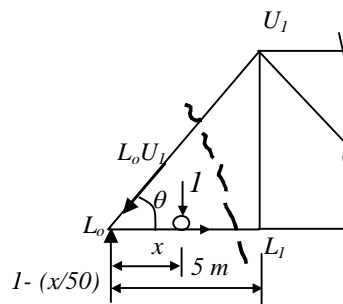

**Fig. E1. Truss arrangement**

**(2) INFLUENCE LINE DIAGRAMS:**

(i) ILD for  $L_0U_1$  (Diagonal member):

**Fig. E2. Free body diagram**



<h1 style="margin: 0;">Structural Steel Design Project</h1> <h2 style="margin: 0;">Calculation Sheet</h2>	Job No:	Sheet 2 of 10	Rev
	Job Title: <i>TRUSS GIRDER RAIL BRIDGE</i>		
	<i>Worked Example - 1</i>		
		Made by SSSR	Date 8-10-00
	Checked by VK	Date	

(a) If, unit load is in between  $L_1$  and  $L_{10}$  (i.e.  $5 \leq x \leq 50$ )

$$\sum V = 0.$$

$$L_0 U_1 \sin \theta = 1 - (x/50) \Rightarrow L_0 U_1 = \frac{1}{\sin \theta} \left( 1 - \frac{x}{50} \right)$$

(b) If, unit load is in between  $L_0$  and  $L_1$  ( i.e.  $0 \leq x \leq 5$  )

$$L_0 U_1 = - \frac{1}{\sin \theta} \frac{9x}{50}$$

Then, we can get ILD as shown in Fig. E3.

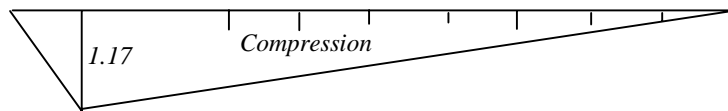

**Fig. E3. ILD for  $L_0 U_1$**

(ii) ILD for  $L_1 U_1$  (Vertical member): [See free body diagram Fig. E4]

(a) If, unit load is in between  $L_0$  and  $L_1$  (i.e.  $0 \leq x \leq 5$ )

$$\sum M_{L_0} = 0.$$

$$5 L_1 U_1 = x$$

$$L_1 U_1 = \frac{x}{5}$$

(b) If, unit load is in between  $L_2$  and  $L_{10}$  (i.e.  $10 \leq x \leq 50$  )

$$L_1 U_1 = 0$$

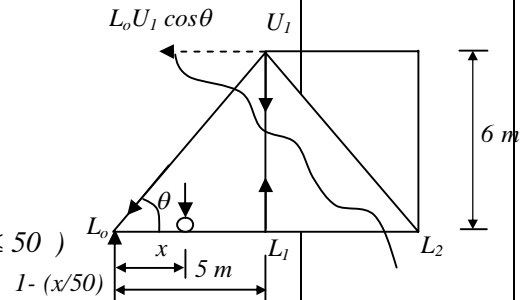

**Fig. E4**



**Fig. E5 ILD for  $L_1 U_1$**

<h1>Structural Steel Design Project</h1> <h2>Calculation Sheet</h2>	Job No:	Sheet 3 of 10	Rev
	Job Title: <i>TRUSS GIRDER RAIL BRIDGE</i>		
	<i>Worked Example - 1</i>		
	Made by SSSR	Date 8-10-00	
	Checked by VK	Date	

(iii) ILD for  $U_4U_5$  and  $L_4L_5$  : (Top and Bottom chord members respectively)

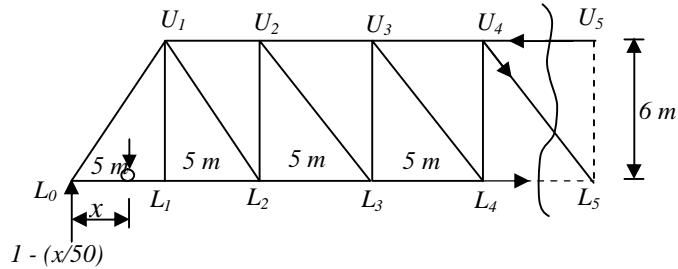

**Fig. E6 Free body diagram**

(a) If, the unit load is in between  $L_0$  and  $L_4$  (i.e.  $0 \leq x \leq 20$  )

$$\sum M_{L_5} = 0$$

$$6U_4U_5 + (25 - x) * 1 = 25 * [1 - (x/50)]$$

$$U_4U_5 = \frac{1}{6} [ 25 ( 1 - \frac{x}{50} ) - ( 25 - x ) ]$$

$$\sum M_{U_4} = 0$$

$$6L_4L_5 + (20 - x) * 1 = 20 * [1 - (x/50)]$$

$$L_4L_5 = \frac{1}{6} [ 20 ( 1 - \frac{x}{50} ) - ( 20 - x ) ]$$

(b) If, unit load is in between  $L_5$  and  $L_{10}$  (i.e.  $25 \leq x \leq 50$  )

$$\text{Then, } U_4U_5 = \frac{1}{6} [ 25 ( 1 - \frac{x}{50} ) ]$$

$$L_4L_5 = \frac{1}{6} [ 20 ( 1 - \frac{x}{50} ) ]$$

ILDs for  $U_4U_5$  and  $L_4L_5$  are shown in Fig. E7 and Fig. E8 respectively.

<h1>Structural Steel Design Project</h1> <h2>Calculation Sheet</h2>	Job No:	Sheet 4 of 10	Rev
	Job Title: <i>TRUSS GIRDER RAIL BRIDGE</i>		
	<i>Worked Example - 1</i>		
		Made by SSSR	Date 8-10-00
	Checked by VK	Date	

**Fig. E7 ILD for U<sub>4</sub>U<sub>5</sub>**

**Fig. E8 ILD for L<sub>4</sub>L<sub>5</sub>**

**(3) LOADS:**

(i) **Dead load** - Dead loads acting on truss girder are as follows:

Weight of rails	=	$2 \times 0.6 = 1.2 \text{ kN/m.}$	RDSO Specifications
*Weight of sleepers	=	$0.25 \times 0.25 \times \frac{7.5}{0.4} = 2.34 \text{ kN/m.}$	
Weight of fastenings (assumed)	=	$0.25 \text{ kN/m.}$	
Weight of stringers (assumed)	=	$3.0 \text{ kN/m}$	
Weight of cross girders (assumed)	=	$5.0 \text{ kN/m.}$	
**Self-weight of truss by Fuller's Formula	=	$13.0 \text{ kN/m}$	
Total dead load per track	=	$24.8 \text{ kN/m}$	
Therefore, Total dead load per girder	=	$\frac{24.8}{2} = 12.4 \text{ kN/m}$	

\*[Assume 250 mm × 250 mm × 2m wooden sleepers @ 400 mm apart and weight of 7.5 kN/m<sup>3</sup>]

\*\*[ Fuller's Formula =  $\frac{15\ell + 550}{100} = \frac{15 \times 50 + 550}{100} = 13.0 \text{ kN/m}$ ]

<h1 style="margin: 0;">Structural Steel Design Project</h1> <h2 style="margin: 0;">Calculation Sheet</h2>	Job No:	Sheet 5 of 10	Rev
	Job Title: <i>TRUSS GIRDER RAIL BRIDGE</i>		
	<i>Worked Example - 1</i>		
		Made by SSSR	Date 8-10-00
	Checked by VK	Date	
<p><b>(ii) Live load</b></p> <p>(a) Areas of Influence line diagrams for truss members discussed:</p> <p>Area of influence line for <math>L_0U_1 = \frac{1}{2} \times 50 \times 1.17 = -29.3</math> (Compression)</p> <p>Area of influence line for <math>L_1U_1 = \frac{1}{2} \times 10 \times 1.0 = +5.0</math> (Tensile)</p> <p>Area of influence line for <math>U_4U_5 = \frac{1}{2} \times 50 \times 2.08 = -52</math> (Compression)</p> <p>Area of influence line for <math>L_4L_5 = \frac{1}{2} \times 50 \times 2 = +50</math> (Tensile)</p> <p><b>(b) Live loads and impact loads from IRS Bridge Rules - 1982:</b></p> <p>Live loads and impact factors for each loaded length are found from <b>IRS Bridge Rules - 1982</b>. For maximum forces in chord members, the whole of the span should be loaded and Live load is determined corresponding to maximum B.M. For other diagonal and vertical members, part of the span as indicated by influence line diagrams, should be loaded and the live load is determined corresponding to S.F. The impact factor is found corresponding to loaded length.</p> <p>For maximum force in members <math>L_4L_5</math> and <math>U_4U_5</math>:</p> <p>Load length = 50 m</p> <p>Live load for B.M. = 3895.2 kN</p> <p>Impact factor = <math>0.15 + \frac{8}{6+l} = 0.15 + \frac{8}{6+50} = 0.293</math></p> <p>(LL+ IL) per m per girder = <math>\frac{3895.2 \times (1+0.293)}{2 \times 50} = 50.36</math> kN/m</p>			

<h1>Structural Steel Design Project</h1> <h2>Calculation Sheet</h2>	Job No:	Sheet 6 of 10	Rev
	Job Title: <i>TRUSS GIRDER RAIL BRIDGE</i>		
	<i>Worked Example - 1</i>		
		Made by SSSR	Date 8-10-00
	Checked by VK	Date	
<p>For maximum force in members <math>L_0 U_1</math> and <math>L_1 U_1</math>:</p> <p><math>L_0 U_1</math>:</p> <p>Load length = 50 m  Live load for B.M. = 4184.6 kN  Impact factor = <math>0.15 + \frac{8}{6+l} = 0.15 + \frac{8}{6+50} = 0.293</math>  <math>(LL+ IL)</math> per m per girder = <math>\frac{4184.6 \times (1+0.293)}{2 \times 50} = 54.1</math> kN/m</p> <p><math>L_1 U_1</math>:</p> <p>Load length = 10 m  Live load for S.F. = 1227.8 kN  Impact factor = <math>0.15 + \frac{8}{6+l} = 0.15 + \frac{8}{6+10} = 0.65</math>  <math>(LL+ IL)</math> per m per girder = <math>\frac{1227.8 \times (1+0.65)}{2 \times 10} = 101.3</math> kN/m</p> <p><b>(c) Longitudinal Loads from IRS Bridge Rules - 1982</b></p> <p>Assume, there exist rail expansion joints in the bridge and prevent the transfer of longitudinal loads to approaches. It may be noted that for broad gauge bridges upto a loaded length of 44 m, the tractive effort is more than the braking force and for loaded lengths more than 44 m the braking force is more than the tractive effort.</p> <p>Assume truss under consideration is simply supported by a hinge at <math>L_0</math> and a roller at <math>L_{10}</math>. The longitudinal force in a member can be tensile or compressive depending on the direction of movement of train.</p> <p>Panel <math>L_4 L_5</math>:</p> <p>Loaded length = 30 m  Tractive effort = 637.4 kN  Force per chord = <math>637.4/2 = \pm 318.7</math> kN</p>			

<b>Structural Steel Design Project</b>	Job No:	Sheet 7 of 10	Rev			
	Job Title: <i>TRUSS GIRDER RAIL BRIDGE</i>					
	<i>Worked Example - 1</i>					
	<b>Calculation Sheet</b>	Made by SSSR	Date 8-10-00			
Checked by VK		Date				
<i>Unfactored loads:</i>						
<i>Member</i>	<i>Area of ILD</i>	<i>Load in kN/m</i>		<i>Forces in members (kN)</i>		
		<i>DL</i>	<i>LL+IL</i>	<i>DL</i>	<i>LL+IL</i>	<i>Long.L</i>
$L_0U_1$	- 29.3	12.4	54.1	-363.3	-1585.1	-
$L_1U_1$	+5.0	12.4	101.3	+ 62	+ 506.5	-
$U_4U_5$	- 52.0	12.4	50.36	-644.8	-2618.7	-
$L_4L_5$	+ 50.0	12.4	50.36	+620	+2518	± 318.7
<i>Use following Partial safety factors for the loads:</i>						
$\gamma_{DL} = 1.35; \gamma_{LL} = 1.50; \gamma_{LongL} = 1.50$						
<i>Factored loads:</i>						
<i>Member</i>	<i>Factored Forces in members (kN)</i>			<i>Total load (kN)</i>		
	<i>DL</i>	<i>LL+IL</i>	<i>Long.L</i>			
$L_0U_1$	-490.4	- 2377.6	-	- 2868.0		
$L_1U_1$	+83.7	+ 759.8	-	+ 843.4		
$U_4U_5$	-870.5	-3928	-	- 4798.5		
$L_4L_5$	+ 837	+3777	± 478	+ 5092	- 478	
<i>Note: Negative sign represents compression and positive sign represents tension.</i>						

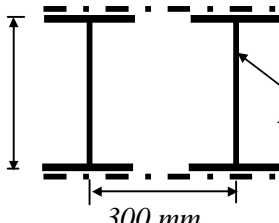
<b>Structural Steel Design Project</b>  <b>Calculation Sheet</b>	Job No:	Sheet 8 of 10	Rev
	Job Title: <i>TRUSS GIRDER RAIL BRIDGE</i>		
	<i>Worked Example - 1</i>		
		Made by SSSR	Date 8-10-00
	Checked by VK	Date	
<p><b>(4) DESIGN FOR TRUSS MEMBERS:</b></p> <p>(i) <b>Design of diagonal member (<math>L_0U_1</math>):</b> Note that in this illustration of this Member, the portal effect and fatigue are not considered.</p> <p>Length of the chord, <math>L_0U_1 = \ell = 7810 \text{ mm}</math></p> <p>Assume, effective length, <math>\ell_e = 0.7*\ell = 5467\text{mm}</math></p> <p>Try a built up member with two ISHB350 spaced @ 300 mm</p> <p><math>A = 18442 \text{ mm}^2</math></p> <p><math>r_x = 146.5 \text{ mm}</math></p> <p><math>r_y = 158.8 \text{ mm}</math></p> <p><math>\lambda_x = 5467/146.5 = 37.3</math></p> <p>Then, <math>\sigma_c = 221.8 \text{ N/mm}^2</math></p> <p>[See chapter on axially compressed columns using curve c]</p> <p>Axial capacity = <math>(221.8/1.15)*18442/1000 = 3556.5 \text{ kN} &gt; 2868 \text{ kN}</math></p> <p><u>Hence, section is safe against axial compression</u></p> <div style="display: flex; align-items: center; justify-content: center;"> <div style="margin-right: 20px;"> <p>350 mm</p> <p>300 mm</p> </div>  <div style="margin-left: 20px;"> <p>ISMB 350</p> </div> </div> <p>(ii) <b>Design of vertical member (<math>L_1U_1</math>):</b></p> <p>Maximum tensile force = 843.4 kN</p> <p>Try ISMB 350 @ 0.524 kN/m shown.</p> <p><math>A = 6671 \text{ mm}^2</math></p> <p>Axial tension capacity of the selected section = <math>6671 * 250/1.15</math>  <math>= 1450 \text{ kN} &gt; 843.4 \text{ kN}</math></p> <p>Hence, section is safe in tension.</p> <p>[Note: Welded connection assumed]</p>			

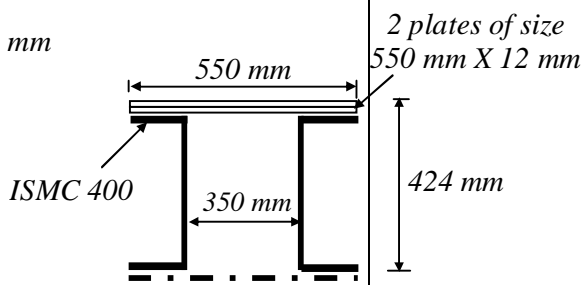
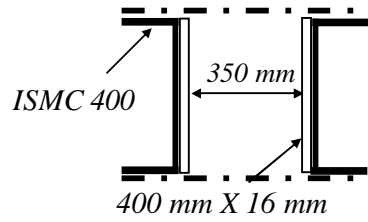

<h1>Structural Steel Design Project</h1> <h2>Calculation Sheet</h2>	Job No:	Sheet 9 of 10	Rev
	Job Title: <i>TRUSS GIRDER RAIL BRIDGE</i>		
	<i>Worked Example - 1</i>		
		Made by SSSR	Date 8-10-00
	Checked by VK	Date	
<p><b>(iii) Design of top chord member (<math>U_4U_5</math>):</b></p> <p>Member length, <math>\ell = 5000 \text{ mm}</math></p> <p>Assume, effective length <math>= 0.85\ell = 4250 \text{ mm}</math></p> <p>Try the section shown.</p> <p><math>A = 25786 \text{ mm}^2</math></p> <p><math>r_x = 165.4 \text{ mm}</math></p> <p><math>r_y = 210 \text{ mm}</math></p> <p><math>\lambda_x = 4250/165.4 = 25.7</math></p> <p>Then, <math>\sigma_c = 239 \text{ N/mm}^2</math></p> <p>[See chapter on axially compressed columns using column curve c]</p> <p>Axial capacity <math>= (239/1.15) * 25786/1000 = 5359 \text{ kN} &gt; 4798.5 \text{ kN}</math></p> <p><u>Hence, section is safe against axial compression</u></p>			
			
<p><b>(ii) Bottom chord design (<math>L_4L_5</math>):</b></p> <p>Maximum compressive force <math>= 478 \text{ kN}</math></p> <p>Maximum tensile force <math>= 5092 \text{ kN}</math></p> <p>Try the box section shown.</p> <p><math>A = 25386 \text{ mm}^2</math></p> <p><math>r_x = 144 \text{ mm}</math></p> <p><math>r_y = 210 \text{ mm}</math></p> <p>Axial tension capacity of the selected section <math>= 25386 * 250/1.15</math>  <math>= 5518 \text{ kN} &gt; 5092 \text{ kN}</math></p> <p>Hence, section is safe in tension.</p>			
			

<h1>Structural Steel Design Project</h1> <h2>Calculation Sheet</h2>	Job No:	Sheet <i>10 of 10</i>	Rev
	Job Title: <i>TRUSS GIRDER RAIL BRIDGE</i>		
	<i>Worked Example - 1</i>		
		Made by SSSR	Date 8-10-00
	Checked by VK	Date	
<p><i>Maximum unrestrained length = <math>\ell = 5000 \text{ mm}</math></i></p> <p style="text-align: center;"><i><math>\lambda_x = 5000/144 = 34.7</math></i></p> <p style="text-align: center;"><i>Then, <math>\sigma_c = 225 \text{ N/mm}^2</math></i></p> <p style="text-align: center;"><i>Axial capacity = <math>(225/1.15) * 25386/1000 = 4967 \text{ kN} &gt; 478 \text{ kN}</math></i></p> <p style="text-align: center;"><u><i>Hence, section is safe against axial compression also.</i></u></p> <p><i>The example is only an illustration. The following have to be taken into consideration:</i></p> <ul style="list-style-type: none"> <li>• <i>Design of lacings/batten</i></li> <li>• <i>Design of connections and effect of bolt holes on member strength</i></li> <li>• <i>Secondary bending effects</i></li> <li>• <i>Design for fatigue</i></li> </ul>			