

BOLTED CONNECTIONS – II

1.0 INTRODUCTION

Connections become complex when they have to transmit axial and shear forces in addition to bending moments, between structural members oriented in different directions. A variety of components such as angle cleats, stiffeners and end plates are used to transfer and also disperse the loads from one member to another. In particular, bolted connections pose additional problems because they employ discrete rather than continuous load paths to effect the transfer. This is in addition to the complex behaviour of the bolts themselves. Attempts to develop complex design procedures which can produce more economical and yet safe connections are rendered futile by the variety of connection configurations possible and more importantly, the variability of behaviour due to practical limitations in fabrication and erection. Therefore the most rational philosophy for design would be to base it on simple analysis and use higher load factors for increased safety. However, it is easier said than done and is fraught with pitfalls unless one develops a certain insight into the behaviour.

In structural design, it is a common tendency to follow a tradition, which has produced satisfactory designs in the past so that one need not worry about having overlooked some important aspect of behaviour. This tendency has crystallised into some standard connection types for which simplified analysis procedures can be used with great advantage. The flange and web angle connection shown in Fig. 1(a) is an example of a typical beam-to-column moment connection. It is important for the novice to become familiar with such connection types and their advantages/disadvantages, which are described in the subsequent sections of this chapter.

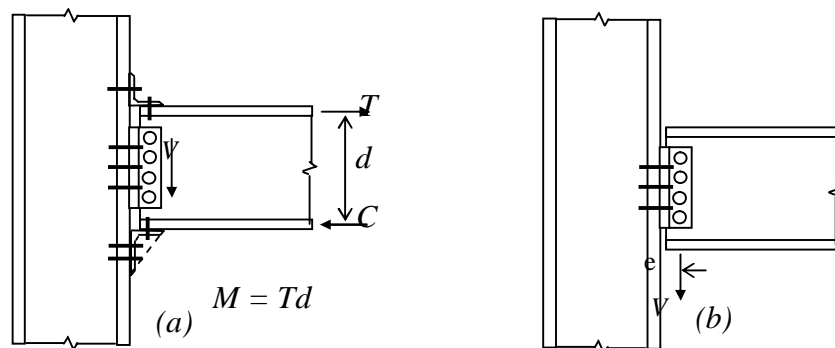

Fig. 1 Standard Connections (a) moment connection (b) simple connection

It is also equally important to remember the assumptions made in traditional analysis so that the elements of the connection are proportioned appropriately. For example, with reference to the connection shown in Fig. 1(a), the angles are assumed to be rigid compared to the bolts. However the top angle will have a tendency to open out while the bottom will have a tendency to close unless sufficiently thick angles are used. Similarly,

© Copyright reserved

the connector behaviour is assumed to be linearly elastic, whereas in reality, if bearing bolts are used, due to the hole size being larger than the bolt shank some slip is likely to take place. This slip may be adequate to release the end moment and make the beam behave as a simply supported one. Therefore it may be advantageous to go for HSFG bolts, which will behave linearly at least at working loads thereby ensuring serviceability of the connection.

Another simplification commonly used is that the distribution of forces is arrived at, by assuming idealised load paths. In the simple connection effected through a pair of short web cleats [Fig. 1(b)], it is assumed that the bolts connecting the beam web and the angles resist only the shear that is transferred. However, if the length of the web cleats is comparable to the depth of the beam, additional shear forces are likely to arise in these bolts due to the eccentricity between the bolt line and the column face and should be considered in design. Further, if the web cleats are unduly stiff, they will satisfy equilibrium but the required rotation for the beam end to act as simply supported may not be possible. Therefore it is important to build ductility into the system by keeping the angles as thin as possible. The aim of the present chapter is to point out these aspects, which will lead to good connection designs.

2.0 ANALYSIS OF BOLT GROUPS

In general, any group of bolts resisting a moment can be classified into either of two cases depending on whether the moment is acting in the shear plane or in a plane perpendicular to it. Both cases are described in this section.

2.1 Combined Shear and Moment in Plane

Consider an eccentric connection carrying a load of P as shown in Fig. 2. The basic assumptions in the analysis are (1) deformations of plate elements are negligible, (2) the total shear is assumed to be shared equally by all bolts and (3) the equivalent moment at the geometric centre (point O in Fig. 2) of the bolt group, causes shear in any bolt proportional to the distance of the bolt from the point O acting perpendicular to the line joining the bolt centre to point O (radius vector).

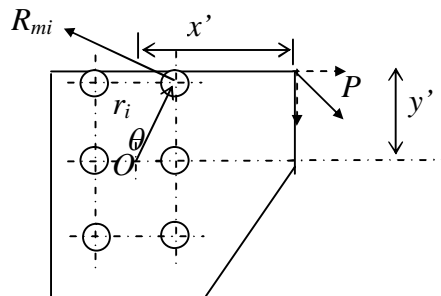

Fig. 2 Bolt group eccentrically loaded in shear

Resolving the applied force P into its components P_x and P_y in x and y -directions respectively and denoting the corresponding force on any bolt i to these shear components by R_{xi} and R_{yi} and applying the equilibrium conditions we get the following:

$$R_{xi} = P_x/n \text{ and } R_{yi} = P_y/n \quad (1)$$

where n is the total number of bolts in the bolt group and R_{xi} and R_{yi} act in directions opposite to P_x and P_y respectively.

The moment of force P about the centre of the bolt group (point O) is given by

$$M = P_x y' + P_y x' \quad (2)$$

where x' and y' denote the coordinates of the point of application of the force P with respect to the point O . The force in bolt i , denoted by R_{mi} , due to the moment M is proportional to its distance from point O , r_i , and perpendicular to it.

$$R_{mi} = k r_i \quad (3)$$

where, k is the constant of proportionality. The moment of R_{mi} about point O is

$$M_i = k r_i^2 \quad (4)$$

Therefore the total moment of resistance of the bolt group is given by

$$MR = \sum k r_i^2 = k \sum r_i^2 \quad (5)$$

For moment equilibrium, the moment of resistance should equal the applied moment and so k can be obtained as $k = M/\sum r_i^2$, which gives R_{mi} as

$$R_{mi} = M r_i / \sum r_i^2 \quad (6)$$

Total shear force in the bolt R_i is the vector sum of R_{xi} , R_{yi} and R_{mi}

$$R_i = \sqrt{\left[(R_{xi} + R_{mi} \cos \theta_i)^2 + (R_{yi} + R_{mi} \sin \theta_i)^2 \right]} \quad (7)$$

After substituting for R_{xi} , R_{yi} and R_{mi} from equations (1) and (6) in (7), using $\cos \theta_i = x_i/r_i$ and $\sin \theta_i = y_i/r_i$ and simplifying we get

$$R_i = \sqrt{\left\{ \left[\frac{P_x}{n} + \frac{M y_i}{\sum (x_i^2 + y_i^2)} \right]^2 + \left[\frac{P_y}{n} + \frac{M x_i}{\sum (x_i^2 + y_i^2)} \right]^2 \right\}} \quad (8)$$

The x_i and y_i co-ordinates should reflect the positive and negative values of the bolt location as appropriate.

2.2 Combined Shear and Moment out-of-plane

In the connection shown in Fig. 3, the bolts are subjected to combined shear and tension. The neutral axis may be assumed to be at a distance of one-sixth of the depth d above the bottom flange of the beam so as to account for the greater area in the compressed portions of the connection per unit depth.

The nominal tensile force in the bolts can be calculated assuming it to be proportional to the distance of the bolt from the neutral axis l_i in Fig. 3. If there exists a hard spot on the compressive load path such as a column web stiffener on the other side of the lower beam flange, the compressive force may be assumed to be acting at the mid-depth of the hard spot as shown in Fig. 3c. In such a case, the nominal tensile force in the bolts can be calculated in proportion to the distance of the bolt from the compressive force ($l_i = L_i$).

$$T_i = kl_i \text{ where } k = \text{constant} \quad (9)$$

$$M = \Sigma T_i L_i = k \Sigma l_i L_i \quad (10)$$

$$T_i = Ml_i / \Sigma l_i L_i \quad (11)$$

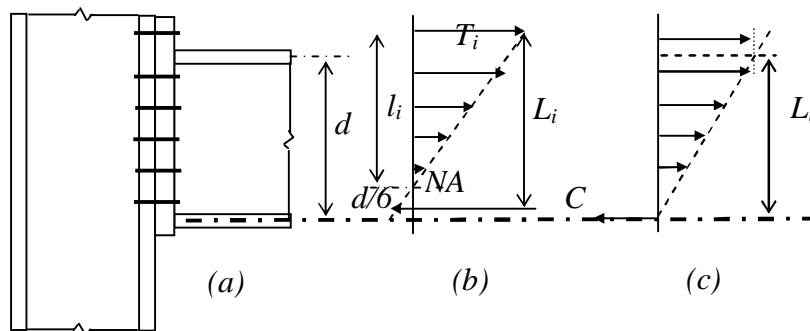

Fig. 3 Bolt group resisting out-of-plane moment

In the case of extended end plate connections, the top portion of the plate behaves as a T-stub symmetric about the tension flange. For calculating the bolt tensions in the rows immediately above and below the tension flange, l_i can be taken as the distance of the tension flange from the neutral axis to the line of action of the compressive force, as the case may be. If the end plate is thin, prying tension is likely to arise in addition to the nominal bolt tension calculated as above.

The shear can be assumed to share equally by all the bolts in the connection. Therefore, the top bolts will have to be checked for combined shear and tension as explained in the previous chapter on Bolted Connections I.

3.0 BEAM AND COLUMN SPLICES

It is often required to join structural members along their length due to the available length of sections being limited and also due to transportation and erection constraints. Such joints are called splices. Splices have to be designed so as to transmit all the member forces and at the same time provide sufficient stiffness and ease in erection. Splices are usually located away from critical sections. In members subjected to instability, the splice should be preferably located near the point of lateral restraint else the splice may have to be designed for additional forces arising due to instability effects.

3.1 Beam Splices

Beam Splices typically resist large bending moments and shear forces. If a rolled section beam splice is located away from the point of maximum moment, it is usually assumed that the flange splice carries all the moment and the web splice carries the shear. Such an assumption simplifies the splice design considerably. Where such simplification is not possible, as in the case of a plate girder, the total moment is divided between the flange and the web in accordance with the stress distribution. The web connection is then designed to resist its share of moment and shear.

A typical bolted splice plate connection is shown in Fig. 4 (a). To avoid deformation associated with slip before bearing in bearing bolts, HSFG bolts should be used. Usually double-splice plates are more economical because they require less number of bolts. However, for rolled steel sections with flange widths less than 200 mm, single splice plates may be used in the flange. End-plate connections may also be used as beam splices [Fig. 4(b)] although they are more flexible.

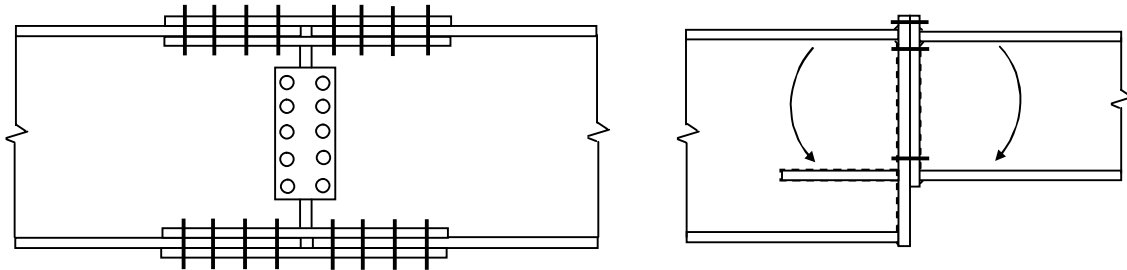

Fig. 4 Bolted Beam Splice: (a) Conventional Splice (b) End-plate Splice

3.2 Column Splice

Column splices can be of two types. In the bearing type, the faces of the two columns are prepared to butt against each other and thus transmit the load by physical bearing. In such cases only a nominal connection needs to be provided to keep the columns aligned. However, this type of splice cannot be used if the column sections are not prepared by grinding, if the columns are of different sizes, if the column carries moment or if continuity is required. In such cases, HSFG bolts will have to be used and the cost of

splice increases. When connecting columns of different sizes, end plates or packing plates should be provided similar to the beam splice shown in Fig. 4(b).

4.0 BEAM-TO-COLUMN CONNECTIONS

Beam-to-column connections can be classified as simple, semi-rigid and rigid depending on the amount of moment transfer taking place between the beam to the column.

Simple connections are assumed to transfer only shear at some nominal eccentricity. Therefore such connections can be used only in non-sway frames where the lateral loads are resisted by some alternative arrangement such as bracings or shear walls. Simple connections are typically used in frames up to about five storeys in height, where strength rather than stiffness govern the design. Some typical details adopted for simple connections are shown in Fig. 5.

The clip and seating angle connection [Fig. 5(a)] is economical when automatic saw and drill lines are available. An important point in design is to check end bearing for possible adverse combination of tolerances. In the case of unstiffened seating angles, the bolts connecting it to the column may be designed for shear only assuming the seating angle to be relatively flexible. If the angle is stiff or if it is stiffened in some way then the bolted connection should be designed for the moment arising due to the eccentricity between the centre of the bearing length and the column face in addition to shear. The clip angle does not contribute to the shear resistance because it is flexible and opens out but it is required to stabilise the beam against torsional instability by providing lateral support to compression flange.

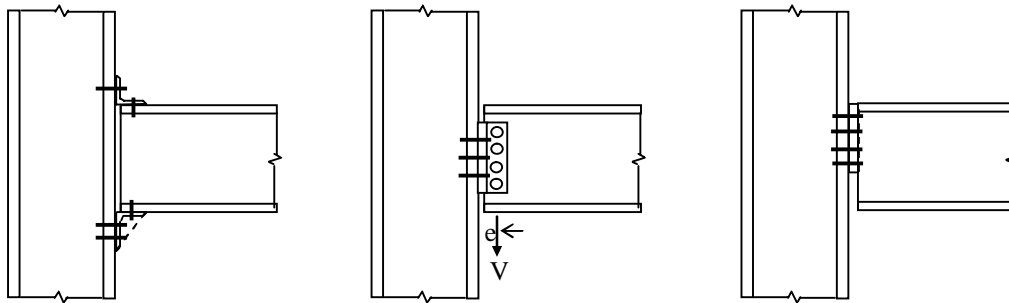

Fig. 5 Simple beam-to-column connections (a) Clip and seating angle (b) Web cleats (c) Curtailed end plate

The connection using a pair of web cleats, referred to as framing angles, [Fig. 5(b)] is also commonly employed to transfer shear from the beam to the column. Here again, if the depth of the web cleat is less than about 0.6 times that of the beam web, then the bolts need to be designed only for the shear force. Otherwise by assuming pure shear transfer at the column face, the bolts connecting the cleats to the beam web should be designed for the moment due to eccentricity.

The end plate connection [Fig. 5(c)] eliminates the need to drill holes in the beam. A deep end plate would prevent beam end rotation and thereby end up transferring significant moment to the column. Therefore the depth of the end plate should be limited to that required for shear transfer. However adequate welding should be provided between end plate and beam web. To ensure significant deformation of the end plate before bolt fracture, the thickness of the end plate should be less than one-half of the bolt diameter for Grade 8.8 bolts and one-third of the bolt diameter for Grade 4.6 bolts.

Rigid connections transfer significant moments to the columns and are assumed to undergo negligible deformations. Rigid connections are necessary in sway frames for stability and also contribute in resisting lateral loads. In high-rise and slender structures, stiffness requirements may warrant the use of rigid connections. Examples of rigid connections are shown in Fig. 6.

Using angles or T-sections to connect beam flanges to the column as shown in Fig. 1 is not economical due to the large number of bolts required. Further, these connections require HSFG bolts for rigidity. Therefore extended end-plate connections have become the popular method for rigid connections. It is fairly easy to transfer about 0.7 to 0.8 times the yield moment capacity of the beam using these connections. Column web stiffening will normally be required and the bolts at the bottom are for preventing the springing action. These bolts can however be used for shear transfer. In the case of deep beams connected to relatively slender columns a haunched connection as shown in Fig. 6c may be adopted. Additional column web stiffeners may also be required in the form of diagonal stiffeners [Fig. 6(b)] or web plates [Fig. 6(c)]. The general design method including prying action is explained in the worked example at the end of this chapter.

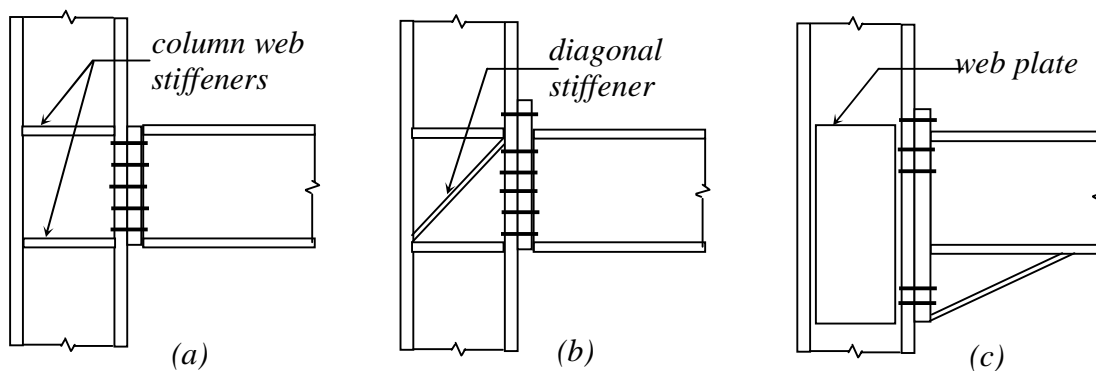

Fig. 6 Rigid beam-to-column connections (a) Short end plate (b) Extended end plate (c) Haunched

Semi-rigid connections fall between the two types mentioned above. The fact that most simple connections do have some degree of rotational rigidity was recognised and efforts to utilise it led to the development of the semi-rigid connections. They are used in conjunction with other lateral load resisting systems for increased safety and performance. Use of semi-rigid connections makes the analysis somewhat difficult but leads to economy in member designs. The analysis of semi-rigid connections is usually

done by assuming linear rotational springs at the supports or by advanced analysis methods, which account for non-linear moment-rotation characteristics.

5.0 BEAMS-TO-BEAM CONNECTION

Beam to beam connections are similar to beam to column connections. Sometimes rigid connections may be provided for moment continuity between secondary beams. In such cases if the primary beam is torsionally flexible, then the torsion transferred to it may be ignored. Typically in simple connections, only web cleats are used because the web of the main beam cannot take a seating angle. For coplanar top flanges, the top flange of the secondary beam may have to be coped and checked for block shear in the design calculations. This is further illustrated in a worked example at the end of this chapter.

6.0 TRUSS CONNECTIONS

Truss connections form a high proportion of the total truss cost. Therefore it may not always be economical to select member sections, which are efficient but cannot be connected economically. Trusses may be single plane trusses in which the members are connected on the same side of the gusset plates or double plane trusses in which the members are connected on both sides of the gusset plates.

It may not always be possible to design connection in which the centroidal axes of the member sections are coincident [Fig. 7(a)]. Small eccentricities may be unavoidable and the gusset plates should be strong enough to resist or transmit forces arising in such cases without buckling (Fig. 7b). The bolts should also be designed to resist moments arising due to in-plane eccentricities. If out-of-plane instability is foreseen, use splice plates for continuity of out-of-plane stiffness (Fig. 7a).

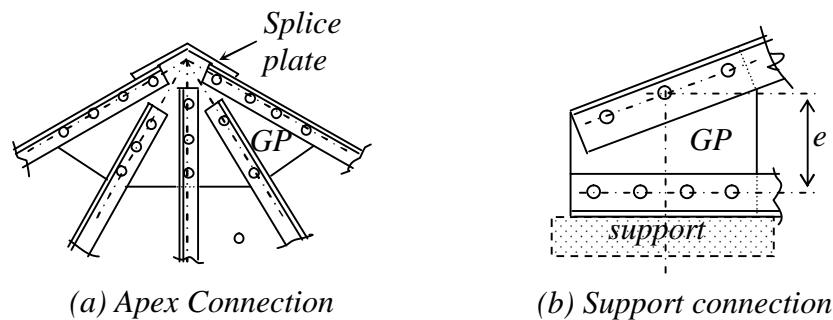

Fig. 7 Truss Connections

7.0 FATIGUE BEHAVIOUR

Fatigue is a phenomenon, which leads to the initiation and growth of cracks in a structure under fluctuating stresses even below the yield stress of the material. The cracks usually initiate from points where stress concentrations occur. Therefore, it is important to ensure that stress concentrations are kept to a minimum in structures subjected to fluctuating stresses. Possible ways of doing this in bolted connections are by using gusset plates of

proper shape, drilling holes more accurately by matching the plates to be connected and using HSFG bolts instead of bearing type bolts. Another aspect, which has a profound effect on the fatigue performance, is the range of stress fluctuations and reversal of stress. By using HSFG bolts, which are pretensioned, stress reversals can be avoided thereby improving the fatigue performance. However, due to the bearing of the bolt head on the plies, these bolts exhibit *fretting corrosion* at the edges of the regions of high bearing pressure.

Fatigue design is usually carried out by means of an S-N curve, which is a plot of the stress range S versus the number of cycles to failure N on a log-log scale. As the stress range decreases, the number of cycles to failure rapidly increases and below a certain level known as the endurance limit, the connection will be able to withstand a sufficiently large number of cycles. The S-N curve is plotted for various types of connections and used for design. Tension connections using HSFG perform extremely well under fatigue. Shear connections using HSFG are better than most welded connections while shear connections using black bolts are inferior to welded connections.

8.0 SUMMARY

The issues involved in the design of connections were described so that the designer can get an insight into the behaviour of various types of connections. Simple analysis methods for bolt groups resisting in-plane and out-of-plane moments were described. Beam and column splices as well as various types of beam-to-column connections were described and their general behaviour as well as points to be kept in mind during their design were explained. In addition, Beam-to-beam and truss connections were also described. Lastly, the topic of fatigue design was touched upon. Finer points in design will be clarified by means of the worked examples at the end of the chapter.